

Lead Free Solder and Flex Cracking Failures in Ceramic Capacitors

N. Blattau, D. Barker, and C. Hillman
CALCE Electronic Products and Systems Center
Building 89, Room 1103
University of Maryland
College Park, MD 20742
Tel.: (301) 405-5323
Fax: (301) 314-9269

Abstract

Many companies have experienced failure of multilayer ceramic capacitors due to printed wiring board bending and have placed controls in their manufacturing process to limit the amount of bending (or flexure) of the PWB to eliminate these failures. The shift to Pb-free solders may require these limits to be adjusted to ensure that MLCC bending failures are avoided. Elastic-plastic finite-element simulations were utilized to study the effects that three different solders have on the durability of a 0805 capacitor as it undergoes a standard three point bend test. The solder attaching a MLCC is a critical path in which printed wiring board loads are transferred into the capacitor, therefore the solder properties play an important role in the durability of ceramic chip capacitors.

Introduction

Surface mount multilayer ceramic capacitors (MLCCs) are one of the most common components found on modern circuit card assemblies. They are well known for their reliability and have been rapidly accepted by the electronics industry. The reliability of a nominal MLCC is extremely high, with expected operating lifetimes in the decades, if not hundreds of years. However, because they rely on ceramic for their structure (Figure 1), MLCCs are known to be susceptible to failure during printed wiring board bending events. Capacitor manufacturers recognize this and typically provide information indicating the capacitors durability to printed wiring board bending through the IEC-384-1 specification and similar documents. A typical test set up for capacitor bend testing is shown in Figure 2.

A critical factor in determining if a capacitor will fail due to PWB bending are the properties of the solder joint. With the acceptance of Pb-free solders the chance of capacitor cracking may change because

many Pb-free solders are stiffer than standard Sn37Pb solder.

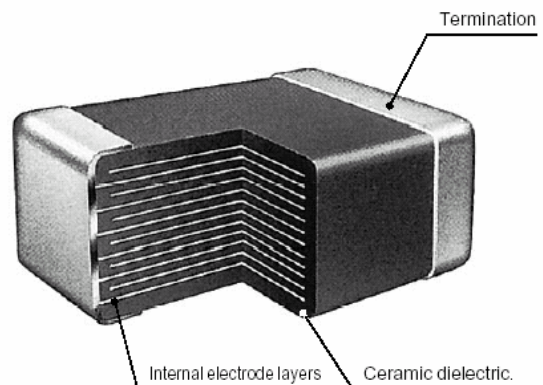

Figure 1: Typical multilayer ceramic capacitor (MLCC) [11]

Capacitor cracks that result from excessive printed wiring board flexure tend to propagate at 45-degree angles from the termination of the end cap. The cracks tend to be large, propagating through the ceramic until it reaches the end cap. A picture of a typical flex crack is displayed in Figure 3.

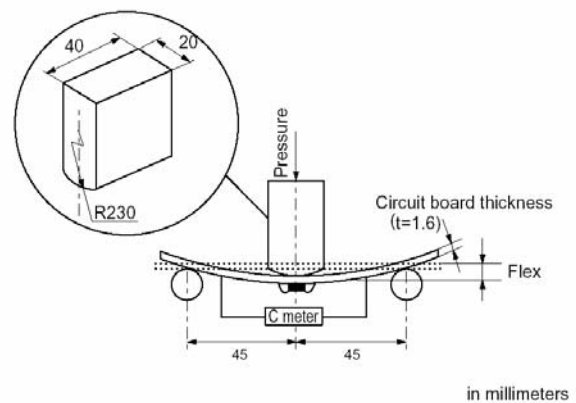

Figure 2: Standard capacitor bend test [11]

In order to avoid designing, manufacturing or using circuit card assemblies in manner that will induce flex cracking in MLCCs, it is important to determine the failure criterion that will cause flex cracks to initiate and what drivers will increase the susceptibility of capacitors to flex cracking.

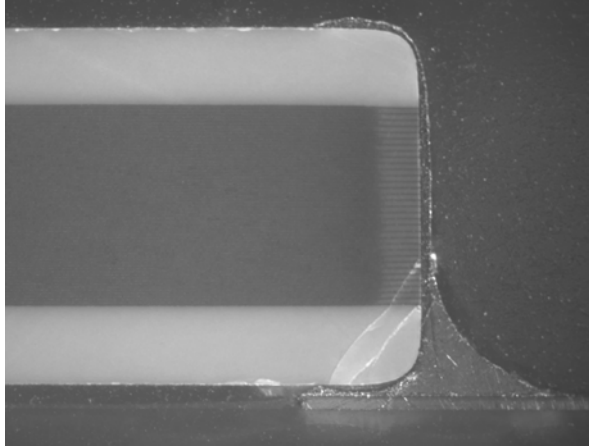

Figure 3: Example of a flex crack in a MLCC [CALCE EPSC]

Flex Cracking

To determine the event that could initiate flex cracking, one must relate the cracking event to a parameter that can be related to its occurrence. In this study the displacement of the printed wiring board is related to the tensile stress in the capacitor using a FEA model. Given displacement failure data from a capacitor manufacturer the failure-stress relationship can be obtained and used to evaluate other types of solders. With this information, an allowable printed wiring board curvature limit can be established that can reduce the occurrence of the flex failures of ceramic capacitors. In this study, a FEA beam model and three point bend failure data [6] from a 0805 capacitor with Sn-37Pb solder interconnects is used to establish the failure stress relationship.

A beam structure is used to approximate the 0805 capacitor mounted to a PWB. The FEA model (shown in Figure 4) uses material properties listed in Table 1 and Table 2. The length of the printed wiring board is 45 mm and the solder is modeled as an elastic-plastic material using a Ramberg-Osgood model as shown in Equation 1 [12]. The stress strain responses of the solders are based on a best fit of available data as shown in Figure 5.

Table 1: Material properties, linear elastic [1, 3, 4]

Material	Elastic Modulus (E: MPa)	Poisson ratio (ν)
Sn-37Pb	35810	0.378
Sn-3.5Ag	39500	0.35
Sn4.0Ag0.5Cu	41000	0.35
FR4	17200	0.159
X7R ceramic	113000	0.34

Table 2: Material properties, nonlinear [1]

Material	Strength coefficient (K)	Hardening exponent (n)
Sn-37Pb	32.8	0.129
Sn-3.5Ag	57.0	0.138
Sn4.0Ag0.5Cu	81.7	0.250

$$\epsilon = \frac{\sigma}{E} + \left(\frac{\sigma}{K} \right)^{\frac{1}{n}}$$

where

K : strength coefficient

σ : stress MPa

n : hardening exponent

ϵ : strain

E : Young's Modulus

Equation 1

Since plasticity of the solder is included, the maximum tensile stress that can be generated is limited.



Figure 4: FEA beam model of 0805 capacitor

The data in indicates that capacitor cracking typically initiates at a flexure of 2.3 mm which corresponds to a tensile stress value in the capacitor of apparently 62 MPa. This compares reasonably well with tensile strength values for BaTiO₃ found in the literature [10].

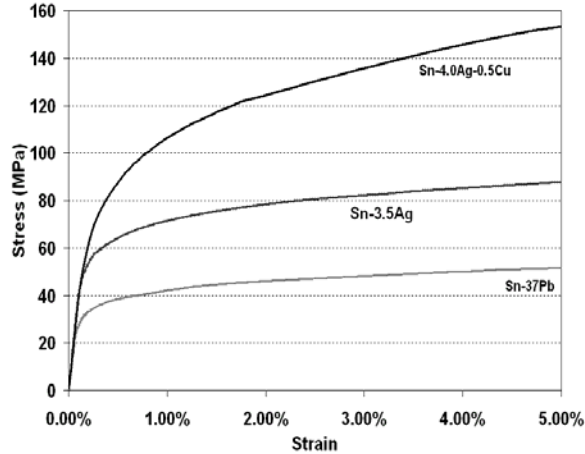

Figure 5: Stress strain curves for three solders, Ramberg-Osgood model fit of available data [1]

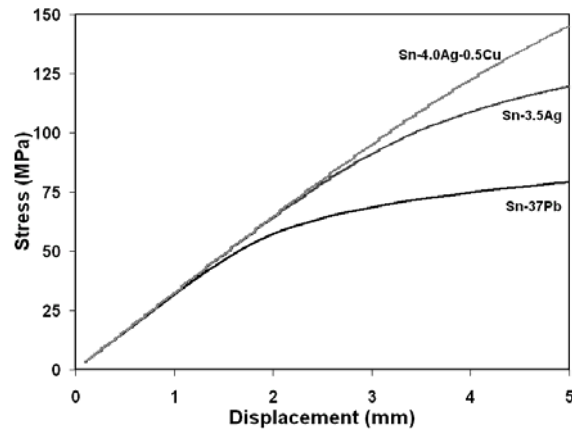

Figure 6: Maximum tensile stress in a 0805 capacitor as a function of PWB flexure/displacement and solder type

By using the results shown in Figure 6 and the experimental test results shown in Table 3 a stress failure relationship for the 0805 capacitor can be developed and used as a failure prediction model for other solder materials (Figure 7).

Using stress as the failure criteria in simple FEA models allows for the failure prediction of capacitors with different types of solder as they undergo a printed wiring board bending event.

Table 3: Results of three-point bend testing of 0805 capacitors [6, 7], test span was 90 mm and test board thickness was 1.6mm

Failure Rate	0.01%	0.1%	1%	10%
Displacement (mm/in.)	2.29 / 0.09	2.67 / 0.11	3.14 / 0.12	3.55 / 0.14
Radius of Curvature (mm/in.)	294.8 / 11.6	252.8 / 9.95	214.9 / 8.46	190.1 / 7.49
Board-Level Strain	2.71E-03	3.16E-03	3.72E-03	4.21E-03

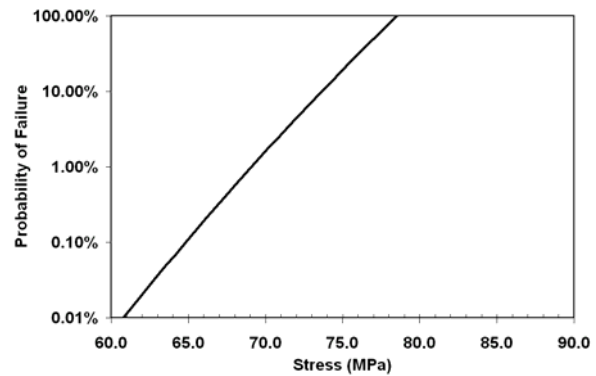

Figure 7: Probability of failure as a function of stress, developed from experimental data and FEA results for the 0805 capacitor with Sn37Pb solder joints

Changing the material properties for the solder and rerunning the model yields the capacitor tensile stress verse printed wiring displacement shown in Figure 6. Using the capacitor stress failure relationship yields the failure displacement results shown in Table 4.

Table 4: FEA results of three point bend tests for Sn37Pb and two lead-free solder alternatives

Probability of Failure	0.01%	0.1%	1%	10%
Solder	PWB Flexure (mm)			
Sn-37Pb	2.29	2.67	3.14	3.55
Sn-3.5Ag	1.89	2.03	2.18	2.33
Sn-4.0Ag-0.5Cu	1.86	1.99	2.13	2.28

These results indicate that changing to either Sn3.5Ag or Sn4.0Ag0.5Cu could lead to an increased chance of capacitor cracking related failures. This is not surprising since both these solders are stiffer and have a higher yield stress [1]. The low yield stress of Sn37Pb solder helps relieve some of the forces transferred to the capacitor from the printed wiring board.

Discussion

While measuring printed wiring board displacement is relatively straight forward it is an inadequate parameter for determining the probability of capacitor flex cracking. This is because the displacement is a function of various parameters and therefore doesn't directly represent the load applied to the capacitor. For example, using simple beam theory for a three point loading, it's easy to show that the force require to deflect a 2.3 mm board can be 3 times the force required to deflect a 1.6 mm board the same amount.

$$P = -\frac{48EI\Delta_{\max}}{L^3}$$

$$I = \frac{bt^3}{12}$$

Equation 2

Where I is the moment of inertia, t is the thickness, E is the elastic modulus, b is the width, L is the span, and Δ is the displacement. It is therefore necessary to use a parameter that is directly related to the forces in the printed wiring board. Assuming the PWB behaves as a beam, a parameter that directly represents the load applied to the PWB would be the radius of curvature or curvature. The moment in the beam is related to the radius of curvature by:

$$\frac{1}{\rho} = \frac{M}{EI}$$

Equation 3

Where I is the moment of inertia of the board, E is the elastic modulus, ρ is the radius of curvature and M is the moment in the board. The curvature can also be related to the strain in the outer fibers of the board by:

$$\varepsilon_{xx} = \frac{t}{2\rho}$$

Equation 4

Where t is the thickness of the board, ε is the board strain at the outer fibers and ρ is the radius of curvature.

The results of the 0805 capacitor three point bends tests and the equivalent printed wiring board radius of curvatures and strains for an allowable failure probability of 0.01% are displayed in Table 5.

Table 5: Allowable limits for a 0805 MLCC at 0.01% failure probability

Solder	Sn37Pb	Sn3.5Ag	Sn4.0Ag 0.5Cu
Displacement (mm)	2.29	1.89	1.86
PWB Strain	2.714E-03	2.240E-03	2.204E-03
Radius of curvature (mm)	294.8	357.1	362.9

Conclusion

The results coupled with an appropriate safety factor could be used as a guideline for allowable flexure when using 0805 capacitors on 1.6 mm thick printed wiring boards. However, the experimental data [6, 7] used in this study was from capacitors specified to a 2 mm deflection limit. Therefore, these guidelines are not applicable to capacitors with a lower or no flexure specification limit.

References

1. S. Wiese, S. Rzepka, E. Meusel, "Time-independent Plastic Behavior of Solders and its Effect on FEM Simulations for Electronics Packages" Advanced Packaging Materials, 2002. Proceedings. 2002 8th International Symposium on , 3-6 March 2002 Page(s): 104 -111
2. S. Wiese, A. Schubert, H. Walter, R. Dudek, F. Feustel, 2001a, "Constitutive Behavior of Lead-free Solders vs. Lead-containing Solders – Experiments on Bulk Specimens and Flip-Chip Joints," ECTC 2001, pp. 890-902, Las Vegas, NV.
3. A. A. Wereszczak, K. Breder, M. K. Ferber, R. J. Bridge, L. Riestler, and T. P. Kirkland, "Failure Probability Prediction of Dielectric Ceramics in Multilayer Capacitors" Proceedings of the International Symposium on Multilayer Ceramic Devices, Transactions of the ACerS, 100th Annual Meeting and Exhibition of the American Ceramic Society, Cincinnati, OH, 1998.
4. A. Dasgupta, C. Oyan, D. Barker and M. Pecht, "Solder Creep-Fatigue Analysis by an Energy-Partitioning Approach," Transactions of the ASME Vol. 114, June 1992, pp 152-160.
5. M. Cozzolino and G. Ewell, "A Fracture Mechanics Approach to Structural Reliability of Ceramic Capacitors," IEEE CHMT, vol. 3, no. 2, pp. 250-57, June 1980.

6. J. Prymak and J. Bergenthal, "Capacitance Monitoring while Flex Testing," IEEE CPMT-A, vol. 18, no. 1, pp. 180-86, March 1995.
7. J. Bergenthal, "Ceramic Chip Capacitors "Flex Cracks": Understanding and Solutions," Kemet Engineering Bulletin F-2111, January 1998.
8. P. Viswanadham and J. Colangelo, "Preventing Passive Component Failures on PCB's," Surface Mount Technology, pp. 64-68, Feb. 1999.
9. Structural Analysis, edited by Russell Hibbeler, Macmillian Publishing, 1990
10. M. K. Shah, "Analysis of Parameters Influencing Stresses in the Solder Joints of Leadless Chip Capacitors", Presented at the ASME Winter Annual Meeting, San Francisco, CA, Dec. 10-15, 1989, ASME Paper No. 89-WA/EEP-31
11. TDK Multilayer Ceramic Chip Capacitors Application Manual, Sept. 1998
12. Ramberg, Walter and Osgood, William R., 1943, "Description of Stress Strain Curves by Three Parameters," Technical Notes National Advisory Committee for Aeronautics No. 902, Washington, D.C.
13. Structural Analysis, edited by Russell Hibbeler, Macmillan Publishing, 1990