

Robustness of Surface Mount Multilayer Ceramic Capacitors Assembled with Pb-Free Solder

Nathan Blattau and Craig Hillman

DfR Solutions, College Park, MD, (301) 474-0607

Patrick Gormally and Vin Iannaccone,

Vishay Vitramon, Inc., Monroe, CT

Laurence Harvilchuck

Universal Instruments Corp., Binghamton, NY

Dr. Nathan Blattau
DfR Solutions

Motivation

- Compare the durability of capacitors attached with SnAgCu solder to those attached with SnPb solder during board flexure
- Determine possible factors that may influence the flexure limit of capacitors attached with SnAgCu solder

Standard Displacement Specification Test

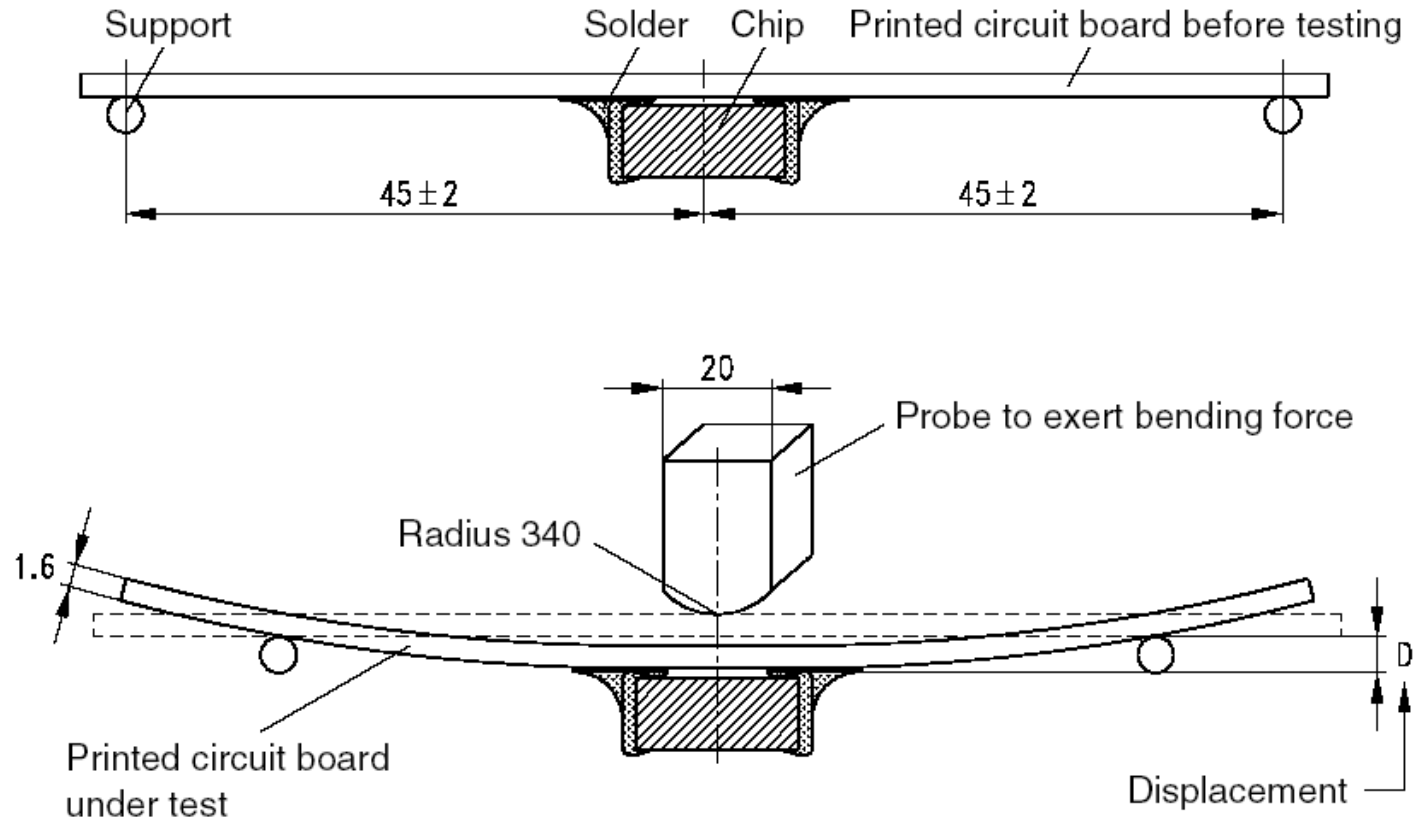

Deflection Specification Examples

Manufacturer	Deflection Specification		
	1 mm	2 mm	Other
AVX		X	X
Vishay	X	X	
Cal-Chip Electronics, Inc.		X	
TDK		X	
EPCOS		X	
MuRata	X		
Syfer, Novacap		X	X
Johanson Dielectrics	X		X
Yageo	X		
Nippon Chemi-Con	X		

AVX offers a soft-termination capacitor with a deflection limit of 5 mm

MuRata - GRM03, GRM15 capacitors, PWB thickness 0.8 mm

Nippon Chemi-Con - Printed wiring board thickness 1.0 mm (1.6 is the standard)

Syfer offers a polymer-termination capacitor with a deflection limit of 5 mm

Johanson - NPO class dielectrics – 1 mm, X7R – 0.5 mm

Sample Population



Capacitor Type	Capacitance (μF)	Solder Composition	Samples Tested
0805 X7R	0.7	SnAgCu	100
1812 X7R	0.5	SnAgCu	200
1812 X7R	0.5	SnPb	100

All capacitors are specified to an allowable deflection of 1 mm

Failure Monitoring

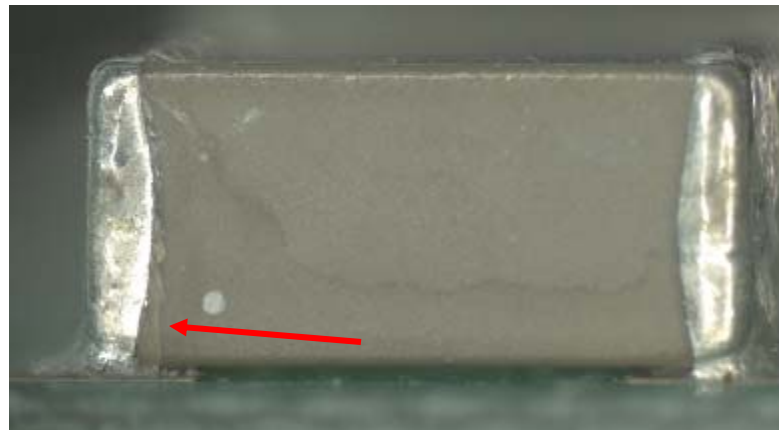

Visible flex crack
1812 Capacitor with
SnAgCu solder

Failure Totals – 1812 Capacitor

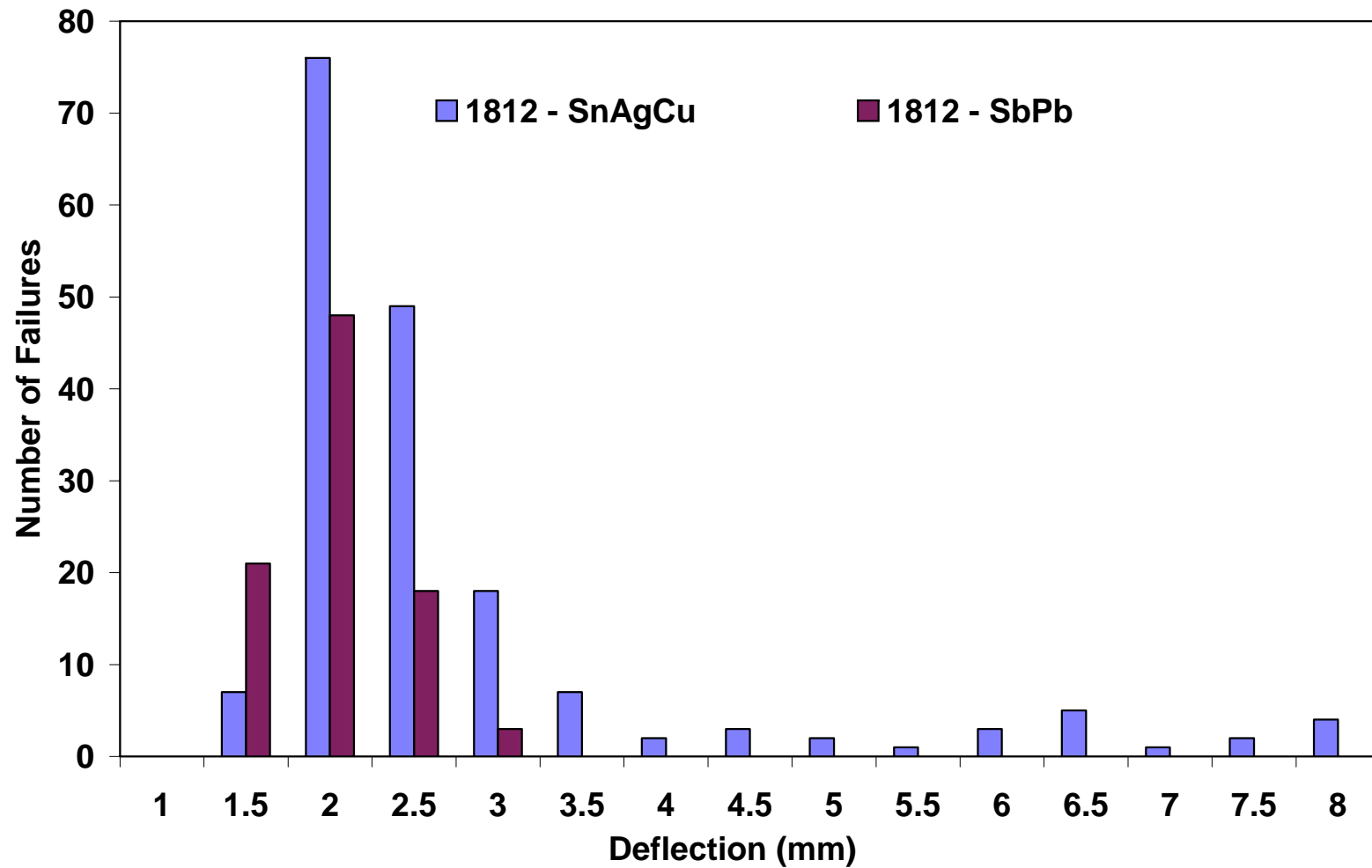

No Failures below 1 mm deflection

Weibull Analysis of Failures - 1812

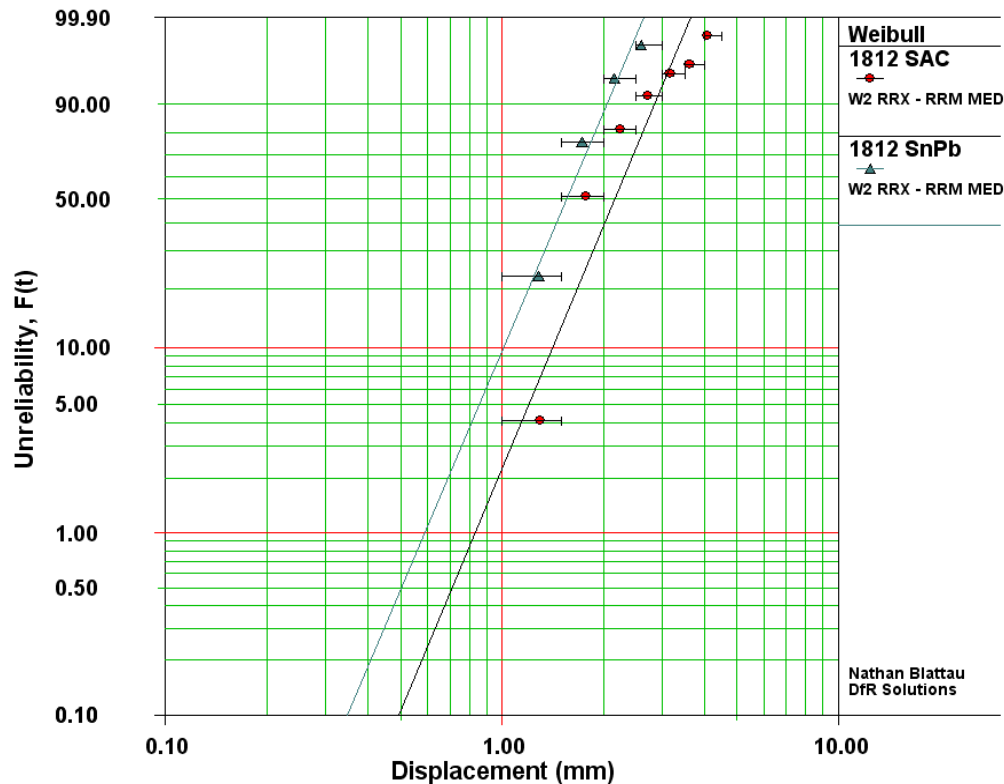

Characteristic displacement (63% failure point) of the SnAgCu 1812 and the SnPb 1812 was 2.36 mm, and 1.70 mm respectively.

$\beta_1=4.4105, \eta_1=2.3551, \rho=0.9306$
 $\beta_2=4.3553, \eta_2=1.6988, \rho=0.9831$

No Failures below 1 mm deflection, failures that occurred about 4.5 mm excluded

Failure Totals – SnAgCu, 0805 Capacitor

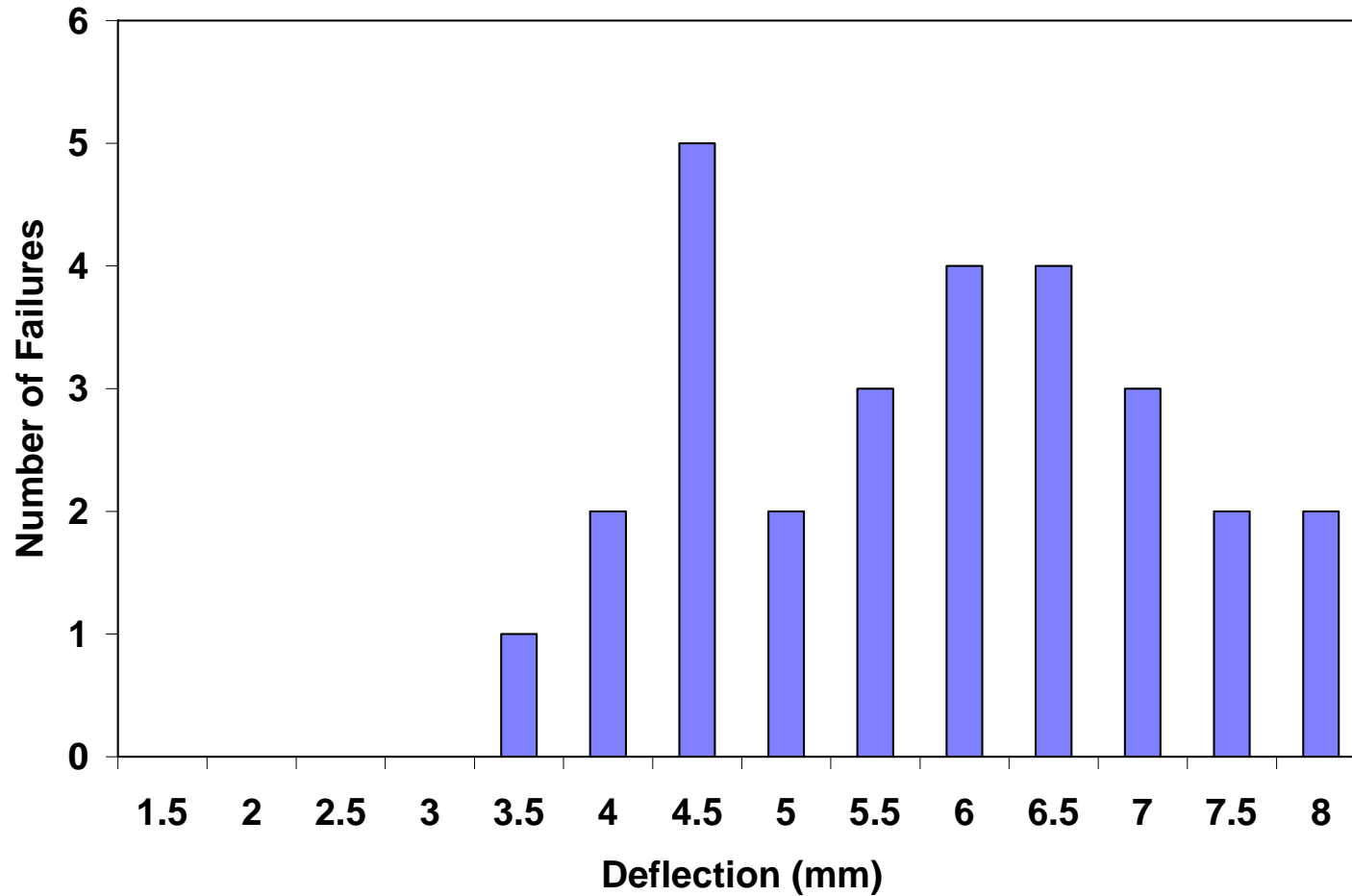

Appears to be bimodal, two distinct populations

Mounting Orientation 0805

Parallel to PWB

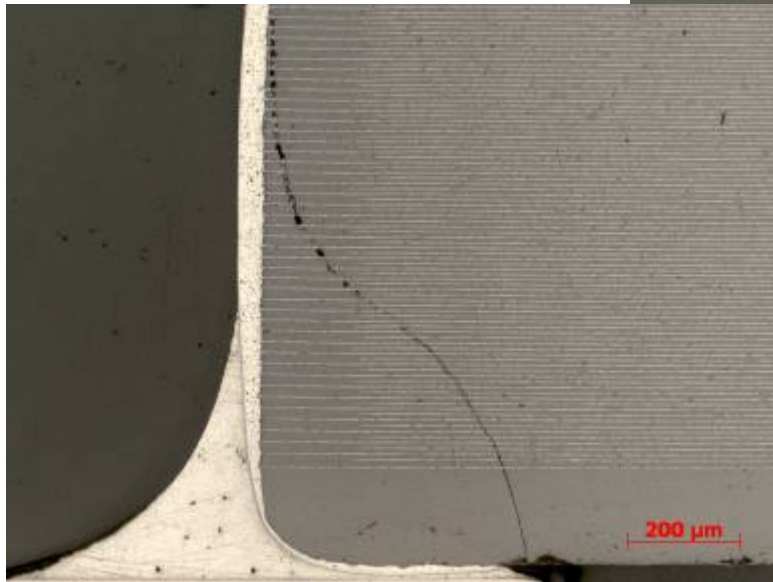

Registered as a failure

Perpendicular to PWB

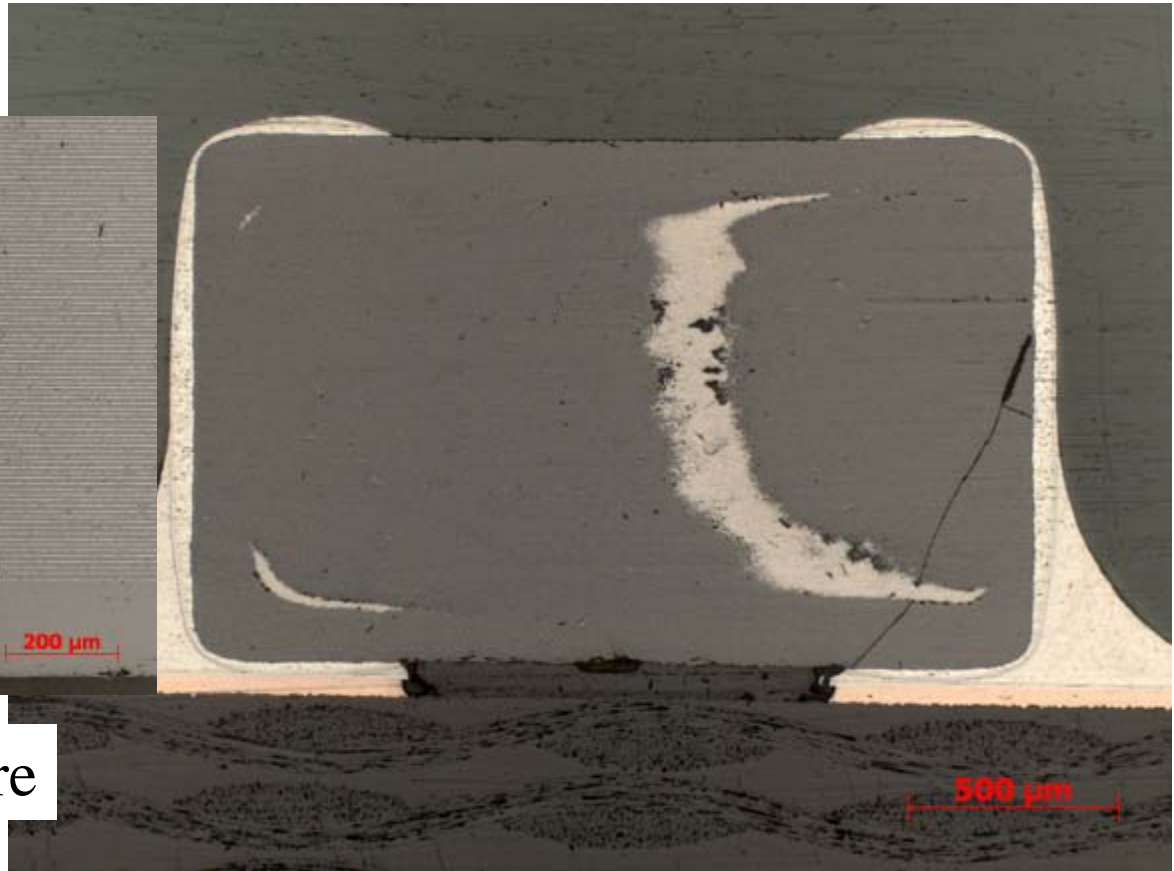

Failure not detected

Weibull Analysis of Failures - 0805

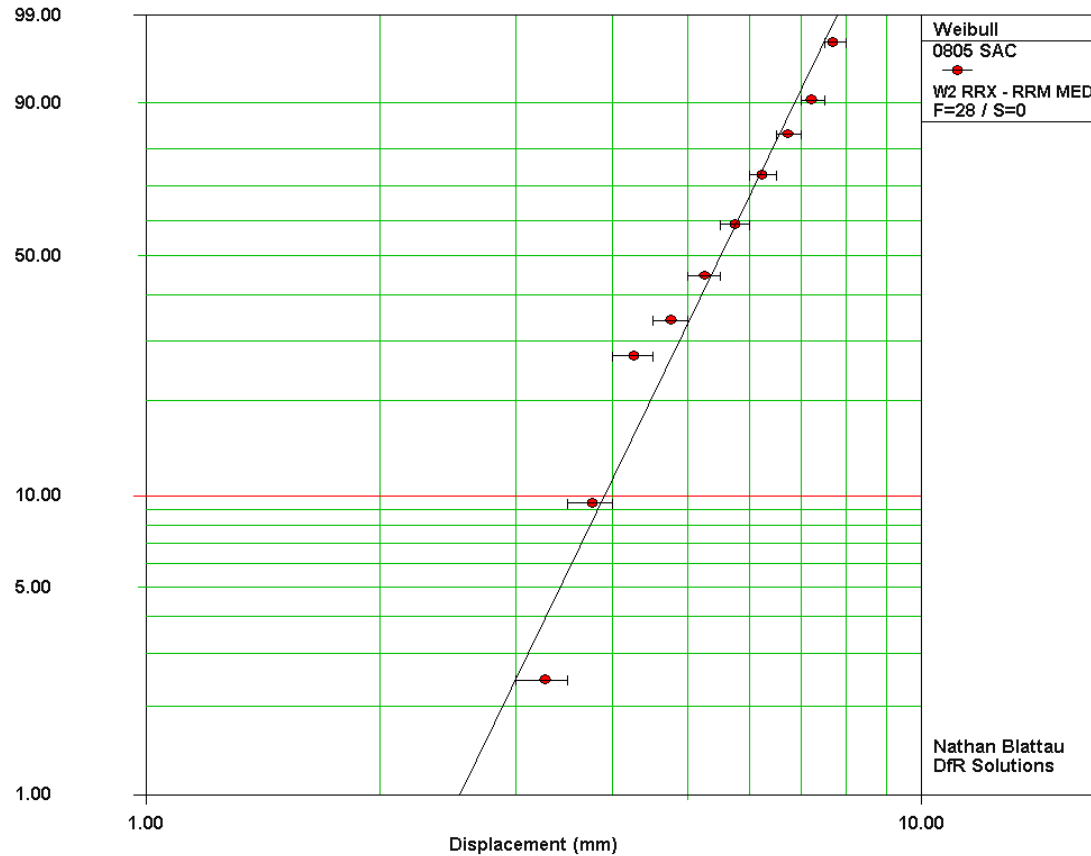

Characteristic displacement
(63% failure point) of the
SnAgCu 0805 is 5.9 mm

$\beta=5.4805, \eta=5.8828, \rho=0.9808$

No Failures below 1 mm deflection, suspended data excluded

Model Predictions

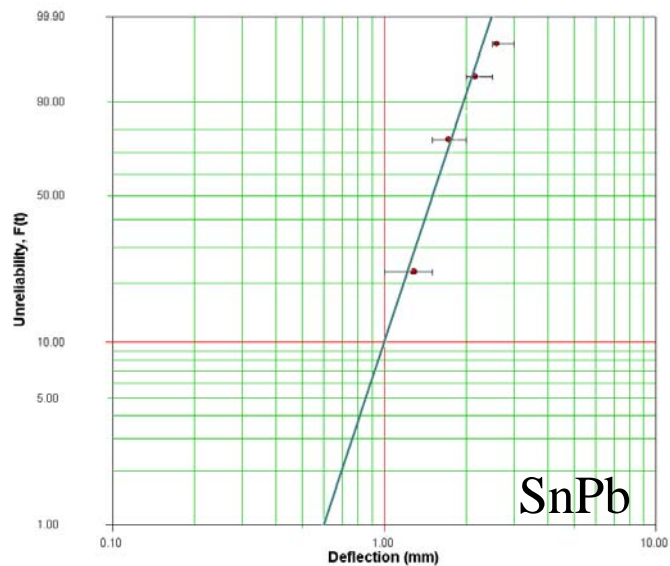
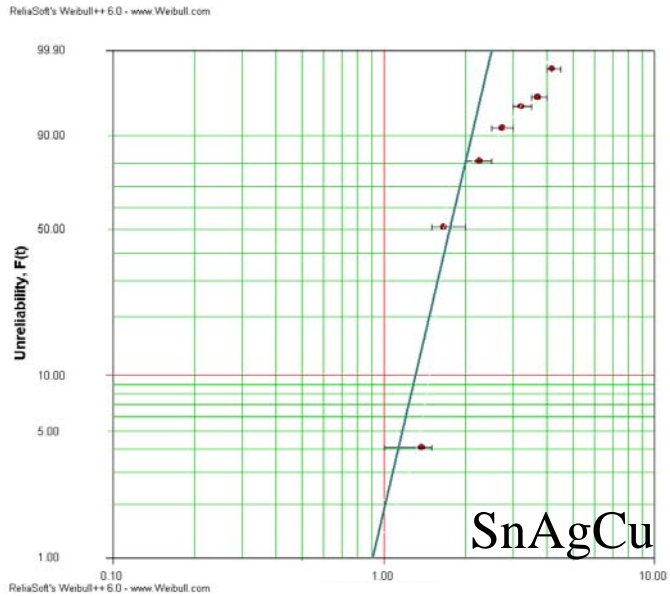

Capacitor Cracking Calculator [v.1.0] - Microsoft Internet Explorer

DfR Solutions
reliability designed, reliability delivered

Capacitor Cracking Calculator

Probability of MLCC Cracking
Due To Printed Wiring Board Bending
Version 3.0

This program calculates the probability of cracking an MLCC during PWB bending. Initially the form contains typical values for each entry; clicking on the Compute button at the bottom of the form will display the corresponding results. This allows the user to compare failure with the results and see some typical results. The capacitor is assumed to be placed on the PWB at the point of greatest deflection.

Reset The Form	Compute
MLCC Manufacturer:	Generic 1 from [m]
Dielectric Type:	XFR [x]
MLCC Size:	1012 [x] Thickness: 0.5 [mm]
Solder Reflow Steps:	standard [x]
Solder Material:	PbSn [x]
Solder Pad Width:	100 [% of chip width (0.5-1.25)]
Solder Pad Length:	0.8 [mm]
Solder Thickness:	0.0254 [mm], Typically between: 0.0254 and 0.127
PWB Thickness:	0.8 [mm]
PWB Modulus:	17300 [MPa]
Applied PWB:	1 [deflection] [inches, 1 inch, mm]
Compute Results:	Compute
Capacitor Stress:	671.23542 [MPa]
Board Moment:	052.41461 [N mm]
Probability of Capacitor Failure:	014.87631 %

Copyright © 2003 by Reliasoft, All Rights Reserved

Apply CapCrackCalc (works) File Computer

Previous FEA and simplified models predicted that capacitors with SAC would be less robust, what did they miss?
Possible answer: Residual compressive stresses in the capacitor due to solder reflow

Stress Relaxation of SnAgCu

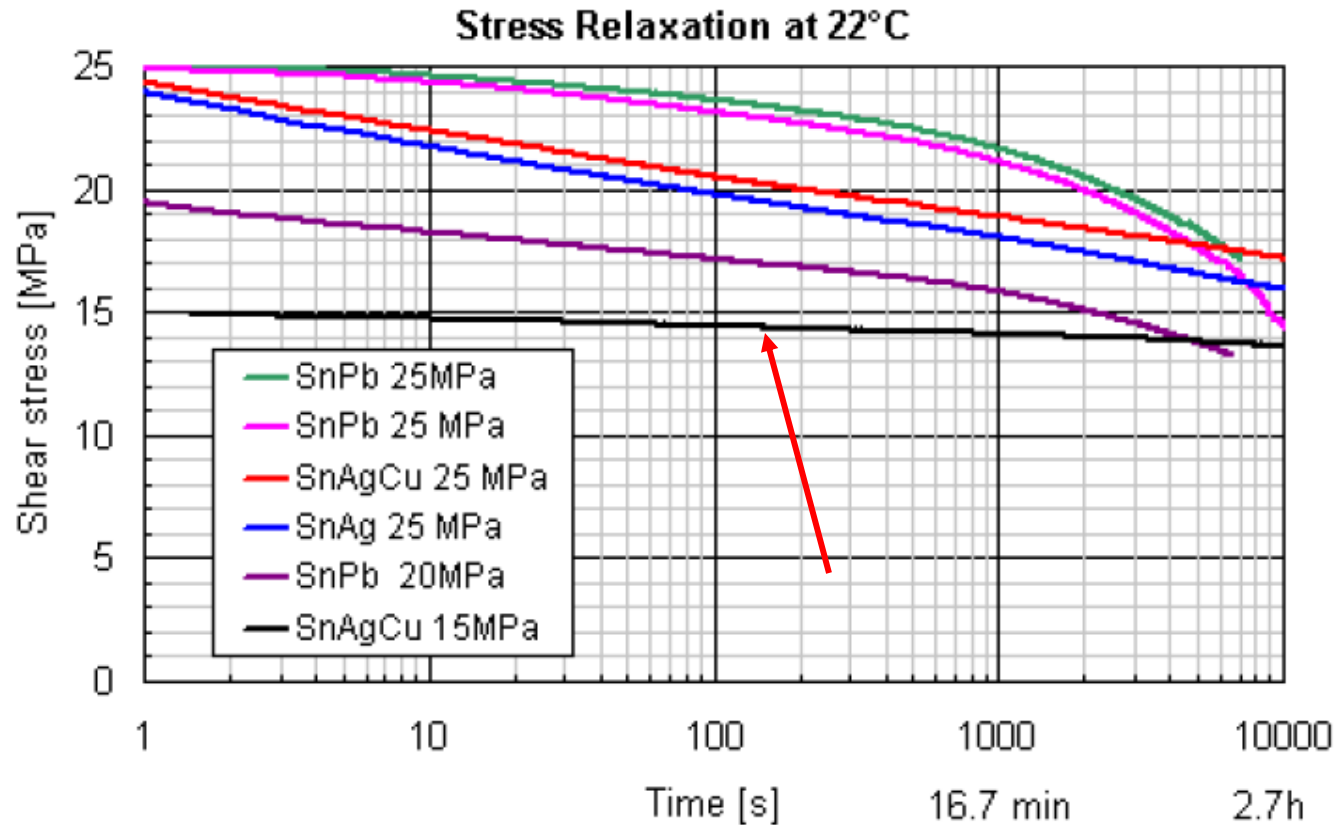

Approximately 0.5 MPa drop per decade, drop to 10 MPa >100 years

Milos Dusek, Chris Hunt, "The Measurement of Creep Rates and Stress Relaxation for Micro-sized Lead-free Solder Joints", NPL Report DEPC MPR 021

Conclusion

- Capacitors solder with SnAgCu solder are more robust than those soldered with SnPb with regards to board flexure
- Capacitor is held in compressive state due to the slower creeping SnAgCu solder
- Good news for ceramic capacitors bad news for BGA components